

Please check the examination details below before entering your candidate information

Candidate surname

Other names

Centre Number

Candidate Number

**Pearson Edexcel**

**Level 1/Level 2 GCSE (9–1)**

# Mock Set 4 – Autumn 2018

(Time: 1 hour 30 minutes)

Paper Reference **1MA1/2H**

## Mathematics

**Paper 2 (Calculator)**  
**Higher Tier**

**You must have:** Ruler graduated in centimetres and millimetres, protractor, pair of compasses, pen, HB pencil, eraser, calculator. Tracing paper may be used.

Total Marks

### Instructions

- Use **black** ink or ball-point pen.
- **Fill in the boxes** at the top of this page with your name, centre number and candidate number.
- Answer **all** questions.
- Answer the questions in the spaces provided – *there may be more space than you need.*
- You must **show all your working**.
- Diagrams are **NOT** accurately drawn, unless otherwise indicated.
- **Calculators may be used.**
- If your calculator does not have a  $\pi$  button, take the value of  $\pi$  to be 3.142 unless the question instructs otherwise.



### Information

- The total mark for this paper is 80
- The marks for **each** question are shown in brackets – *use this as a guide as to how much time to spend on each question.*

### Advice

- Read each question carefully before you start to answer it.
- Keep an eye on the time.
- Try to answer every question.
- Check your answers if you have time at the end.

Turn over ►

S59728A

©2018 Pearson Education Ltd.

1/1/1



  
Pearson

**Answer ALL questions.**

**Write your answers in the spaces provided.**

**You must write down all the stages in your working.**

**1** Divide 7560 in the ratio 4:5

..... , .....

**(Total for Question 1 is 2 marks)**

DO NOT WRITE IN THIS AREA

DO NOT WRITE IN THIS AREA

DO NOT WRITE IN THIS AREA



DO NOT WRITE IN THIS AREA

DO NOT WRITE IN THIS AREA

DO NOT WRITE IN THIS AREA

2 Here is a Venn diagram.

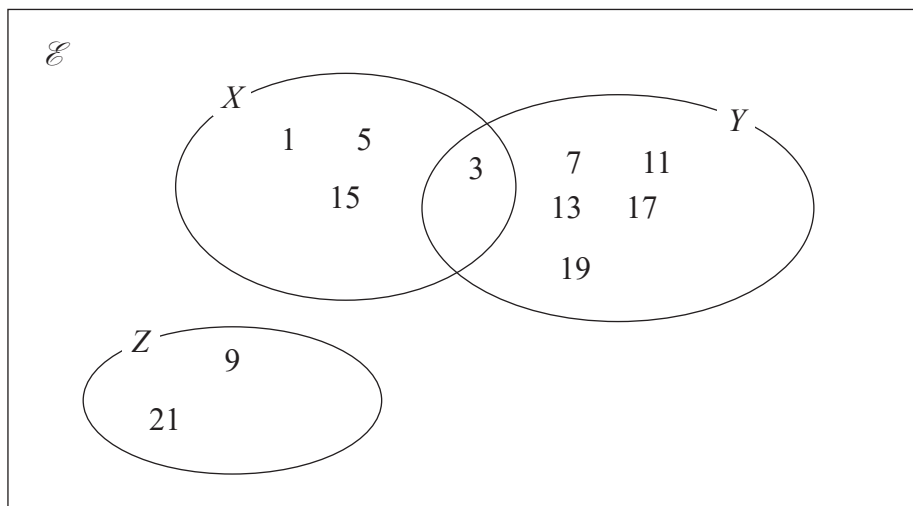

(a) List the members of

(i)  $X$

.....  
(1)

(ii)  $X \cap Y$

.....  
(1)

(iii)  $X \cup Z$

.....  
(1)

A number is chosen at random from  $\mathcal{E}$ .

(b) Find the probability that this number is in  $Y \cup Z$ .

.....  
(2)

(Total for Question 2 is 5 marks)



3  $ABC$  is a right-angled triangle.

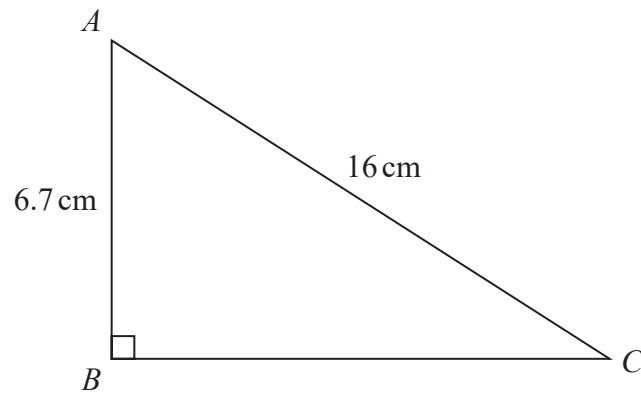

Calculate the length of  $BC$ .  
Give your answer correct to 1 decimal place.

..... cm

(Total for Question 3 is 3 marks)



DO NOT WRITE IN THIS AREA

DO NOT WRITE IN THIS AREA

DO NOT WRITE IN THIS AREA

4 (a) Write  $1.04 \times 10^5$  as an ordinary number.

.....  
(1)

(b) Write 0.06 in standard form.

.....  
(1)

$4.62 \times 10^8$  tins of beans were sold last year.  
These tins of beans cost a total of £300.3 million.

(c) Work out the average cost per tin of beans.

£.....  
(2)

**(Total for Question 4 is 4 marks)**

5 Becky buys a new car for £25 000

The value of this car will depreciate

by 20% at the end of the first year  
and then by 12% at the end of every year after the first year.

Work out the value of the car at the end of 3 years.

£.....

**(Total for Question 5 is 3 marks)**



6 The diagram shows a shape made from a trapezium  $ABCD$  and a semicircle with diameter  $DC$ .

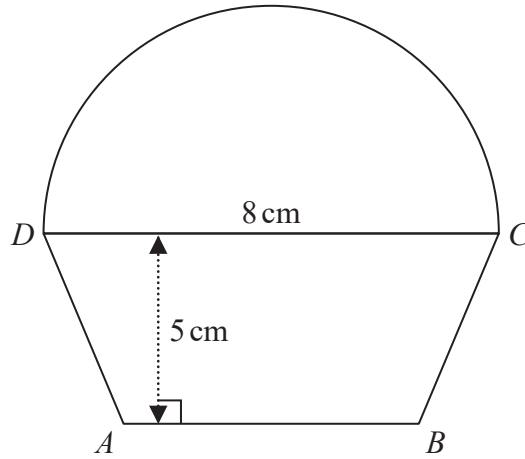

$DC = 8 \text{ cm}$

The shape has area  $64 \text{ cm}^2$

The height of the trapezium is  $5 \text{ cm}$ .

Work out the length of  $AB$ .

Give your answer correct to 1 decimal place.

..... cm

(Total for Question 6 is 5 marks)



DO NOT WRITE IN THIS AREA

DO NOT WRITE IN THIS AREA

DO NOT WRITE IN THIS AREA

7 On Monday 4 bricklayers took 3 hours to lay a total of 4200 bricks.

On Tuesday there are only 2 bricklayers.

Work out how many hours it will take the 2 bricklayers to lay a total of 3150 bricks.

..... hours

**(Total for Question 7 is 3 marks)**

8 Simon invested an amount of money in a savings account at 0.5% per annum compound interest. At the end of 3 years, the amount of money in the savings account was £12 180.90

Work out how much money Simon invested in the savings account.  
You must show your working.

£.....

**(Total for Question 8 is 3 marks)**



9

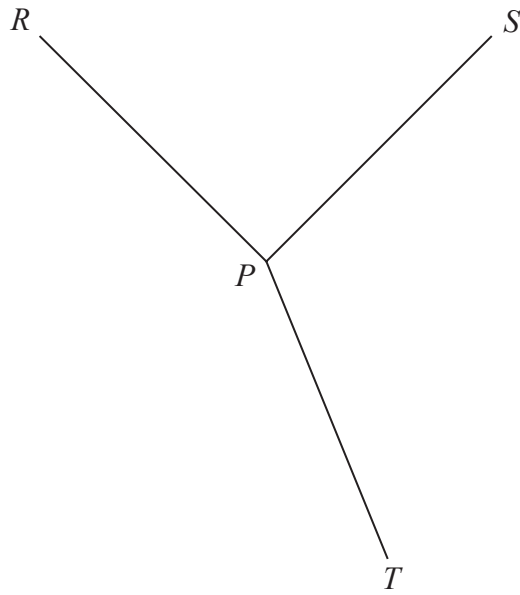

$PR$  and  $PS$  are two sides of a square.

$PS$  and  $PT$  are two sides of a regular pentagon.

$PR$  and  $PT$  are two sides of a regular polygon with  $n$  sides.

Work out the value of  $n$ .

You must show your working.

$n = \dots\dots\dots$

(Total for Question 9 is 4 marks)

DO NOT WRITE IN THIS AREA

DO NOT WRITE IN THIS AREA

DO NOT WRITE IN THIS AREA

8





DO NOT WRITE IN THIS AREA

DO NOT WRITE IN THIS AREA

DO NOT WRITE IN THIS AREA

10 Solve the simultaneous equations

$$2x + 3y = 6$$

$$7x - 2y = 1$$

$$x = \dots\dots\dots$$

$$y = \dots\dots\dots$$

(Total for Question 10 is 4 marks)



- 11 The incomplete table and the incomplete box plot give information about the number of lorries using a bridge each day last January.

	Number of lorries
Least number	
Lower quartile	
Median	
Upper quartile	280
Greatest number	405

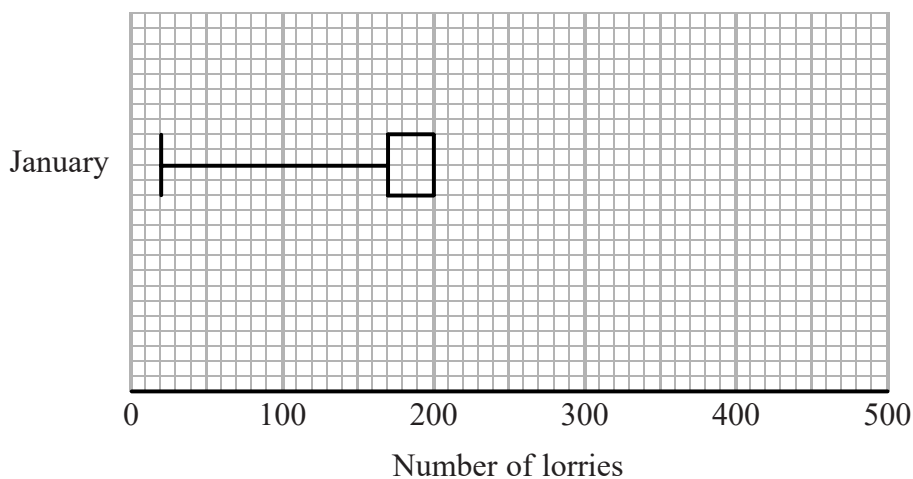

- (a) (i) Use the information in the table to complete the box plot.  
(ii) Use the information in the box plot to complete the table.

(2)



DO NOT WRITE IN THIS AREA

DO NOT WRITE IN THIS AREA

DO NOT WRITE IN THIS AREA

The box plot below gives information about the number of lorries using the bridge each day last February.

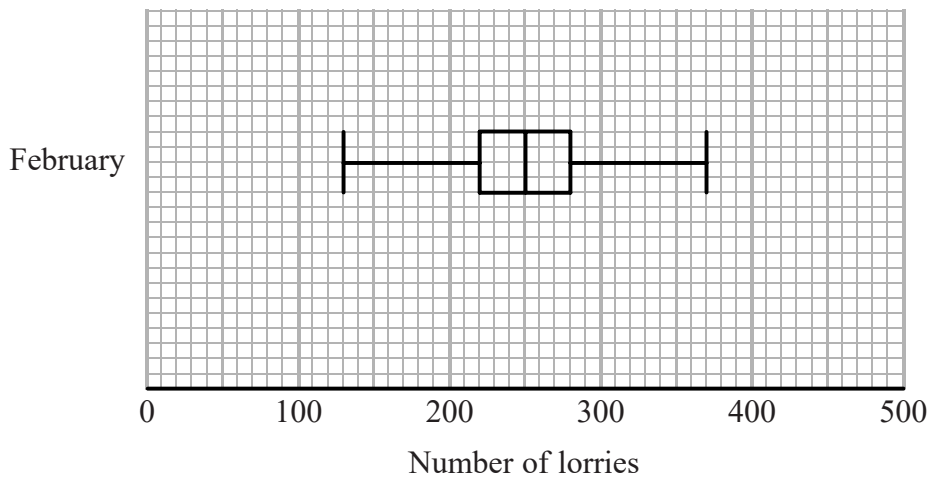

(b) Compare the distribution of the number of lorries using the bridge last January and the distribution of the number of lorries using the bridge last February.

.....

.....

.....

.....

(2)

(Total for Question 11 is 4 marks)



12  $ABCDEFGH$  is a cuboid.

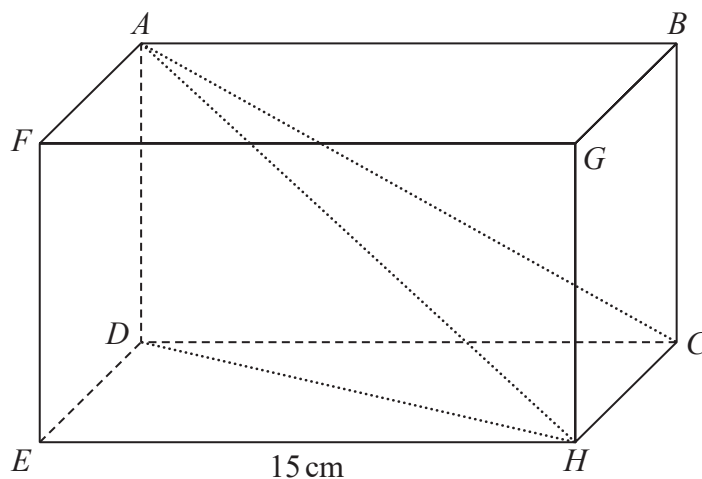

Angle  $EDH = 64^\circ$

Angle  $ACD = 28^\circ$

$EH = 15$  cm

Work out the size of angle  $AHD$ .

Give your answer correct to 1 decimal place.

DO NOT WRITE IN THIS AREA

DO NOT WRITE IN THIS AREA

DO NOT WRITE IN THIS AREA

(Total for Question 12 is 4 marks)



DO NOT WRITE IN THIS AREA

DO NOT WRITE IN THIS AREA

DO NOT WRITE IN THIS AREA

13  $(6^{-2})^w = 6^8$

(a) Find the value of  $w$ .

$w = \dots\dots\dots$   
(1)

$\frac{(a^r)^2}{(a^t)^3}$  can be written in the form  $a^u$

(b) Find an expression for  $u$  in terms of  $r$  and  $t$ .

$\dots\dots\dots$   
(2)

Given that  $n^{\frac{2}{3}} = 8$  and  $n > 0$

(c) work out the value of  $n$ .

Give your answer in the form  $a\sqrt{b}$  where  $a$  and  $b$  are integers.

$\dots\dots\dots$   
(2)

(Total for Question 13 is 5 marks)



14 There are some flowers in a shop.

Each flower is either red or yellow.

Each flower is either a tulip or a rose.

For these flowers

number of tulips : number of roses = 6 : 5

number of red tulips : number of yellow tulips = 3 : 4

Work out the proportion of the flowers that are red tulips.

.....  
(Total for Question 14 is 3 marks)

DO NOT WRITE IN THIS AREA

DO NOT WRITE IN THIS AREA

DO NOT WRITE IN THIS AREA



DO NOT WRITE IN THIS AREA

DO NOT WRITE IN THIS AREA

DO NOT WRITE IN THIS AREA

15 Alison has some shapes.

She has 14 red cubes and 10 red spheres.  
She has 12 black cubes and 8 black spheres.

Alison is going to select 2 of these shapes.

Of these 2 shapes

- only 1 can be red
- only 1 can be black
- only 1 can be a cube
- and only 1 can be a sphere.

In how many ways can Alison select the 2 shapes?

.....  
(Total for Question 15 is 2 marks)



16 The graph of  $y = x^2$  is reflected in the line with equation  $y = x$  to give the curve C.

- (a) Sketch the graph of  $y = x^2$  and the curve C.  
Clearly label the graphs.

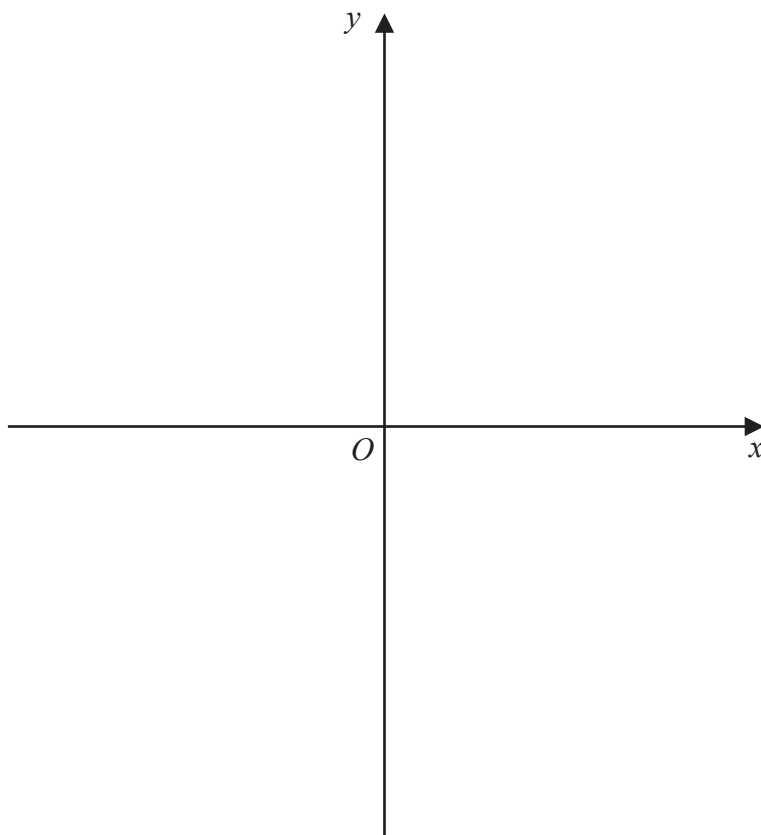

(3)

DO NOT WRITE IN THIS AREA

DO NOT WRITE IN THIS AREA

DO NOT WRITE IN THIS AREA





(b) Here are seven graphs.

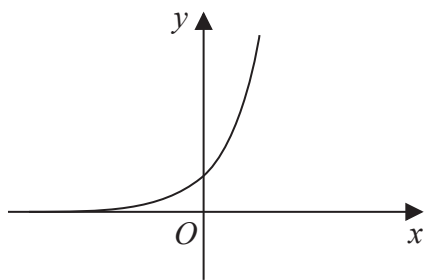

Graph A

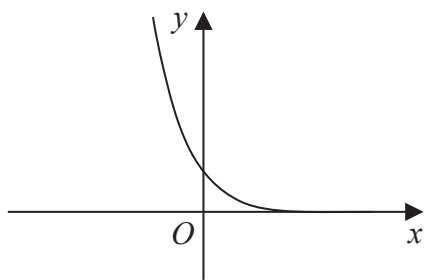

Graph B

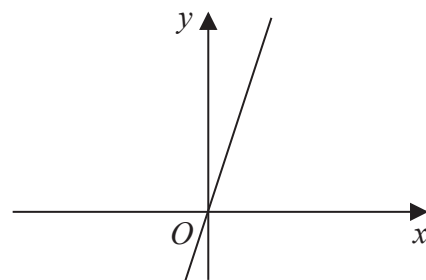

Graph C

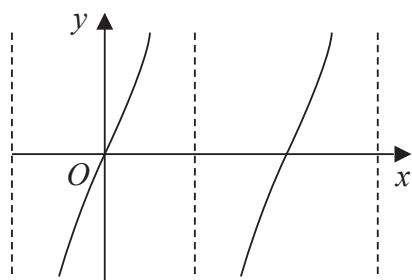

Graph D

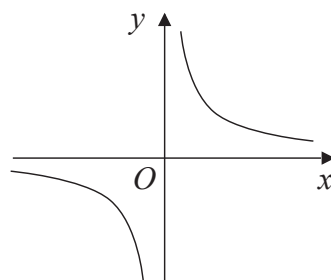

Graph E

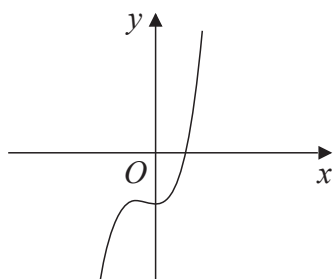

Graph F

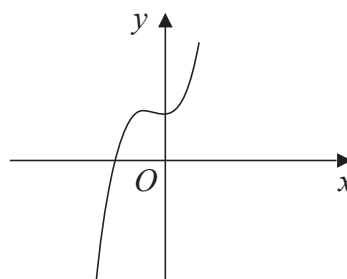

Graph G

Complete the table below with the letter of the graph that could represent each given equation.

Equation	Graph
$y = 3^x$	
$y = \tan x^\circ$	
$y = x^3 + x^2 + 2$	
$y = \frac{3}{x}$	

(3)

(Total for Question 16 is 6 marks)

DO NOT WRITE IN THIS AREA

DO NOT WRITE IN THIS AREA

DO NOT WRITE IN THIS AREA



- 17 The number of moose in Alaska at the start of year  $n$  is  $P_n$   
The number of moose in Alaska at the start of the following year is given by

$$P_{n+1} = 1.04(P_n - G) \quad \text{where } G \text{ is a constant.}$$

At the beginning of 2015, there were 200 000 moose in Alaska.

At the beginning of 2016, there were 200 720 moose in Alaska.

Work out how many moose there were in Alaska at the beginning of 2017

.....  
(Total for Question 17 is 4 marks)

DO NOT WRITE IN THIS AREA

DO NOT WRITE IN THIS AREA

DO NOT WRITE IN THIS AREA



DO NOT WRITE IN THIS AREA

DO NOT WRITE IN THIS AREA

DO NOT WRITE IN THIS AREA

18 Solve the inequality  $2x^2 + x - 3 < 0$   
Represent the solution set on the number line.

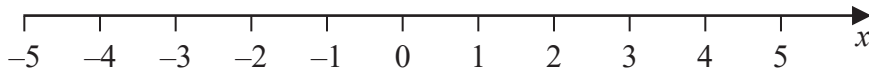

(Total for Question 18 is 4 marks)



19  $OAB$  is a triangle.

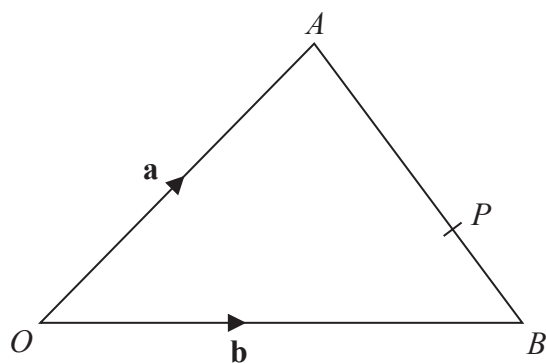

$$\vec{OA} = \mathbf{a}$$

$$\vec{OB} = \mathbf{b}$$

$P$  is the point on  $AB$  such that  $AP:PB = 3:2$

Find  $\vec{OP}$  in terms of  $\mathbf{a}$  and  $\mathbf{b}$ .

Give your answer in its simplest form.

.....  
(Total for Question 19 is 3 marks)



DO NOT WRITE IN THIS AREA

DO NOT WRITE IN THIS AREA

DO NOT WRITE IN THIS AREA

20  $f(x) = \frac{1-x}{1+x}$

(a) Show that  $ff(x) = x$

(3)

(b) Hence, write down  $f^{-1}(x)$

.....  
(1)

(Total for Question 20 is 4 marks)



21 There are only red counters, yellow counters and blue counters in a bag.

Kevin takes at random a counter from the bag.

He puts the counter back in the bag.

Lethna takes at random a counter from the bag.

She puts the counter back in the bag.

The probability that both counters are red or that both counters are yellow is  $\frac{13}{36}$

The probability that the first counter is red and the second counter is not red is  $\frac{1}{4}$

Seb takes at random a counter from the bag.

Work out the probability that Seb takes a yellow counter.

You must show all your working.

.....  
(Total for Question 21 is 5 marks)

---

TOTAL FOR PAPER IS 80 MARKS



DO NOT WRITE IN THIS AREA

DO NOT WRITE IN THIS AREA

DO NOT WRITE IN THIS AREA

**BLANK PAGE**



DO NOT WRITE IN THIS AREA

DO NOT WRITE IN THIS AREA

DO NOT WRITE IN THIS AREA

**BLANK PAGE**

